



1 HP SHALLOW WELL PUMP

OPERATING MANUAL



⚠ WARNING:

Read carefully and understand **RULES FOR SAFE OPERATION** and instructions before operating.

Failure to follow the safety rules and other basic safety precautions may result in serious personal injury.

Item # 109231

SPECIFICATIONS

Motor	120 V, 60 Hz, Single Phase
No load speed	3400 rpm
Discharge size	1" Diameter
Flow898 GPH @ 5 Feet;
.....	845 GPH @ 25 Feet
Max. suction depth	26 Feet
Max. lift	98 Feet
Pressure tank capacity	4.4 Gallon
Max. pressure	72 PSI

SAVE THIS MANUAL

You will need the manual for the safety warnings and precautions, assembly instructions, operating and maintenance procedures, parts list and diagram. Keep your invoice with this manual. Write the invoice number on the inside of the front cover. Keep the manual and invoice in a safe and dry place for future reference.

SAFETY WARNINGS AND PRECAUTIONS

⚠ WARNING! When using tool, basic safety precautions should always be followed to reduce the risk of personal injury and damage to equipment.

READ ALL WARNINGS AND INSTRUCTIONS BEFORE USING THIS TOOL

1. **KEEP WORK AREA CLEAN.** Cluttered areas invite injuries.
2. **OBSERVE WORK AREA CONDITIONS.** Do not expose this pump to rain or direct immersion. Don't expose to rain. Keep work area well lighted. Do not use electrically powered tools in the presence of flammable gases or liquids.
3. **KEEP CHILDREN AWAY.** Children must never be allowed in the work area. Do not let them handle Pump..
4. **USE THE RIGHT PUMP FOR THE JOB.** Do not attempt to force a small pump to do the work of a larger industrial pump. There are certain applications for which this pump was designed. It will do the job better and more safely at the rate for which it was intended. Do not modify this pump and do not use this pump for a purpose for which it was not intended.
5. **DRESS PROPERLY.** Do not wear loose clothing or jewelry as they can be caught in moving parts. Protective, electrically nonconductive clothes and nonskid footwear are recommended when working. Wear restrictive hair covering to contain long hair.
6. **USE EYE AND EAR PROTECTION.** Always wear ANSI approved impact safety goggles and ear protection.
7. **DO NOT OVERREACH.** Keep proper footing and balance at all times. Do not reach over or across running machines.
8. **MAINTAIN PUMP WITH CARE.** Keep pump clean for better and safer performance. Inspect tool cords periodically; If damaged, have them repaired by a qualified technician.
9. **DISCONNECT POWER.** Unplug pump when not in use.

10. **STAY ALERT.** Watch what you are doing, use common sense. Do not install pump when you are tired.
11. **CHECK FOR DAMAGED PARTS.** Before using pump, any part that appears damaged should be carefully checked to determine that it will operate properly and perform its intended function. Check for alignment and binding of moving parts; any broken parts or mounting fixtures; and any other condition that may affect proper operation. Any part that is damaged should be properly repaired or replaced by a qualified technician.
12. **GUARD AGAINST ELECTRIC SHOCK.** Prevent body contact with grounded surfaces such as pipes, radiators, ranges, and refrigerator enclosures.
13. **REPLACEMENT PARTS AND ACCESSORIES.** When servicing, use only identical replacement parts. Use of any other parts will void the warranty. Only use accessories intended for use with this tool.
14. **DO NOT INSTALL PUMP IF UNDER THE INFLUENCE OF ALCOHOL OR DRUGS.** Read warning labels on prescriptions to determine if your judgment or reflexes are impaired while taking drugs. If there is any doubt, do not install the pump.
15. **USE PROPER SIZE AND TYPE EXTENSION CORD.** If an extension cord is required, it must be of the proper size and type to supply the correct current to the tool without heating up. Otherwise, the extension cord could melt and catch fire, or cause electrical damage to the tool. This tool requires use of an extension cord of 0 to 10 amps capability (up to 50 feet), with wire size rated at 18 AWG. Longer extension cords require larger size wire. If you are using the tool outdoors, use an extension cord rated for outdoor use (signified by "WA" on the jacket).
16. **MAINTENANCE.** For your safety, maintenance should be performed regularly by a qualified technician.

⚠ WARNING: People with pacemakers should consult with their physician(s) before using this product; operation of equipment in close proximity to a heart pacemaker could cause interference or failure of the pacemaker.

⚠ WARNING: Never operate this pump if the power cord or electrical components are damaged or the seals are compromised. Never plug in the power cord when wet or standing on damp or wet ground. Exercise extreme caution when working with electrical equipment in the presence of water to maintain your personal insulation to avoid shock. Do not allow others in the work area when working with electrical equipment. Use GFCI outlets when using this pump.

Noted: Performance of this tool (if powered by line voltage) may vary depending on variations in local line voltage. Extension cord usage may also affect tool performance.

⚠ Warning: The warnings, cautions, and instructions discussed in this instruction manual cannot cover all possible conditions and situations that may occur. It must be understood by the operator that common sense and caution are factors which cannot be built into this product, but must be supplied by the operator.

UNPACKING

When unpacking, check to make sure the parts listed on pages 7 and 8 are included. If any parts are missing or broken, please call Northern Tool + Equipment at the number on the cover of this manual as soon as possible.

INSTALLATION

Note: For intake and discharge hose locations, see FIGURE 1 on page 5.

Note: If power cords must be extended, only use UL approved power cords that are 18 Gauge wire. Do not extend the power cords more than 50 feet.

1. Install the pump on a rigid, level platform above the water level. This platform must provide a solid, level surface that is capable of supporting the weight of the pump, and attached piping filled with water. Never allow the pump to become immersed in water.
2. The level of the intake port should not be more than 12-15 feet above the water. Pumping efficiency falls off as the height above the water level increases.
3. Keep the vertical lift that the pump must move water before discharge, to a minimum. Vertical delivery above a few feet will decrease pump efficiency.
4. The intake port must have a screen (not included) attached to prevent introduction of debris into the pump. At the end of the discharge pipe, either purchase a pre-made screen to fit, or wrap loose screen and secure with wire.

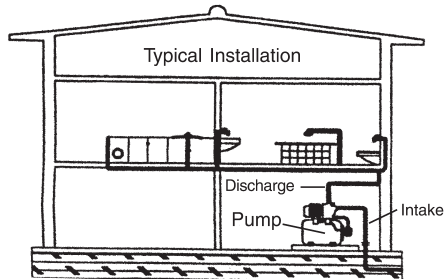

5. **Note:** A foot valve (not included), installed on the suction inlet, is recommended to insure that the pump will keep it prime.
5. Lay out the intake and discharge pipes with as few turns as possible to prevent air pockets within the lines. Air pockets interfere with pressure switch performance.
6. Intake and discharge pipes must have a minimum of 1" to 1-1/4" diameter. Systems with larger vertical components should have larger diameter piping. Keep in mind that the maximum vertical lift (total vertical distance from the inlet screen to the discharge outlet) is 140 feet.
7. For your protection, the power outlet used should have a Ground Fault Circuit Interrupter (GFCI). Have it installed by a qualified electrician. Keep the power line safely away from water.
8. The inlet and discharge lines should not be wedged or stressed in a way that puts strain on the pump. Do not support the pump with the inlet and discharge lines.
9. This is a self starting pump that uses a pressure switch. Once the power cord is connected, the pump can start at any time. **Do not handle or perform maintenance on the pump if the power cord is plugged in.**

Note: Compression Tank has a rubber bladder inside. This bladder must be pumped up with between 18 and 19 PSI of air at all times. On the end of the Compression Tank opposite the side with the Pressure Meter, is an air valve located under a cover. Remove the cover over the air valve and periodically monitor this air valve with an air pressure gauge to insure that the rubber bladder maintains the required 18 to 19 PSI.

OPERATION

⚠ WARNING! Never pump liquids containing abrasive materials such as sand. Never pump flammable, corrosive, or volatile liquids.

⚠ WARNING! Never plug in the power cord when wet or standing on damp or wet ground. Do not plug in the power cord until step number 4 below..

Figure 1

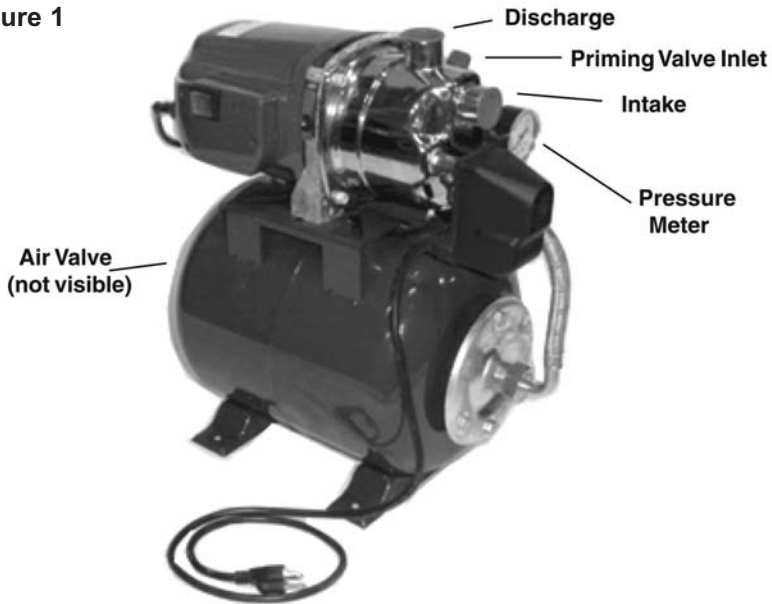

1. Make sure the intake pipe is fully submerged before operating the pump.
2. Gently insert a screwdriver into the motor shaft and make sure the shaft turns freely.(See Figure 1)
3. Important Note: Before starting the pump for the first time, prime it by pouring clean water into the Priming Valve Inlet (see Figure 1). If water leaks from the drainvalve underneath the pump, securely close it and refill the unit.

NOTE: It is necessary that you install a foot valve (not included), if you are drawing water from a source that is lower than the pump. The foot valve should be installed on the bottom of the inlet pipe. A foot valve is a one way valve that will only allow the water to flow in one direction. This should prevent the need to prime the pump every time you use it by keeping the water in the inlet pipe from draining out after the pump is turned off. Check the pump for prime each time you use it. Running the pump dry will damage it.

4. To begin pumping, plug in the power cord.

TROUBLESHOOTING

Problem	Cause	Solution
The pump won't start	No power Blocked Impeller Pressure switch disconnected Thermal Protection cut out	Check connections Free the motor shaft Check gauge Allow pump to cool
The pump operates but it won't discharge water	Inlet tube not submerged Air in suction pipe Inlet screen clogged Lifting height exceeded	Submerge the inlet Check pipe and seals Clean screen Reduce lifting height
Pump has low capacity	Inlet pipe is too small Liquid is too dirty Lifting height exceeded Tank's rubber bladder underinflated.	Increase pipe diameter Clean screen frequently Reduce lifting height Inflate to 18- 19 PSI

Never disassemble the pump or motor as this will damage the water seals. All repairs should be performed by a qualified technician.

MAINTENANCE

Always disconnect pump from power source before attempting any maintenance.

1. Clean the inlet screen regularly to remove accumulated debris.
2. Use air pressure gauge to test air pressure in Tank's rubber bladder. Air pressure should range between 18 and 19 PSI.
3. Wipe the pump clean with a soft, damp cloth with soapy water. Do not use solvents. Do not get the electrical components wet.
4. If storing the pump for a long time, store it in a dry location, and apply a light layer of oil to the metal parts prior to storage, to inhibit rust.
5. To drain the pump, disconnect the water lines and turn it up side down.

PARTS LIST

Part	Description	Qty.
1	Screw M8x12	4
2	Motor Housing	1
3	Fan Blade	1
4	Rear Cover	1
5	Spring Washer	1
6	Motor Bolt M5x125	4
7	Stator	1
8	Bearing	1
9	Rotor	1
10	Bearing	1
11	Rubber Sheath	1
12	Screw 4.2x15	2
13	Cable Block	1
14	Cable Sleeve	1
15	Connection Cable	1
16	Screw 2.9x15	4
17	Waterproof Cover	1
18	Rubber Cover	1
19	O-ring	1
20	Capacitor Cover	1
21	Capacitor	1
22	Side Cover	1
23	Switch Seal Plate	1

Part	Description	Qty.
24	Waterproof Switch	1
25	Screw 3.5 x 20	3
26	Hex Nut M8x20	4
27	Front Cover	1
28	Rubber Ring	1
29	O-ring	1
30	Flange	1
31	Immobile Ring	1
32	Motor Ring	1
33	Impeller	1
34	Flow Guide Plate	1
35	O-ring	1
36	Flow Guide Assy.	1
37	O-ring	1
38	Pump Shell	1
39	Lg. Valve Cover	2
40	Large Bushing	1
41	Sealed Latex	1
42	Screw M8x20	4
43	O-ring	1
44	Small Bushing	1
45	Small Valve Cover	1

ASSEMBLY DRAWING

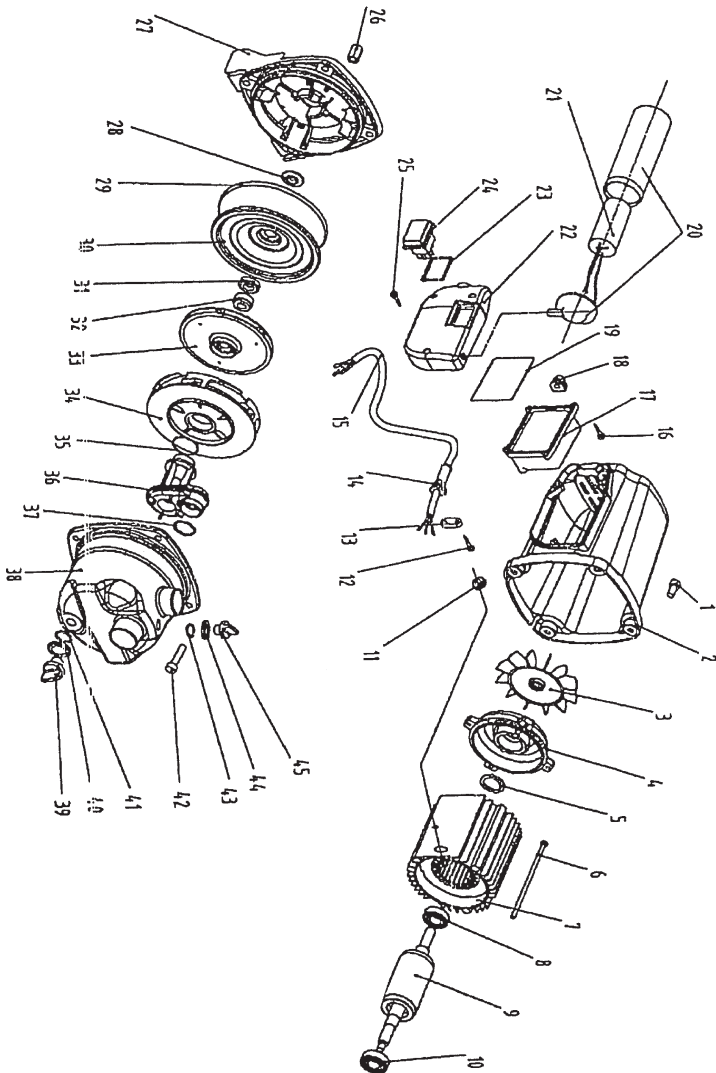

ASSEMBLY DRAWING A

Note: When ordering a part from this drawing, you must include the suffix "A" with the number.

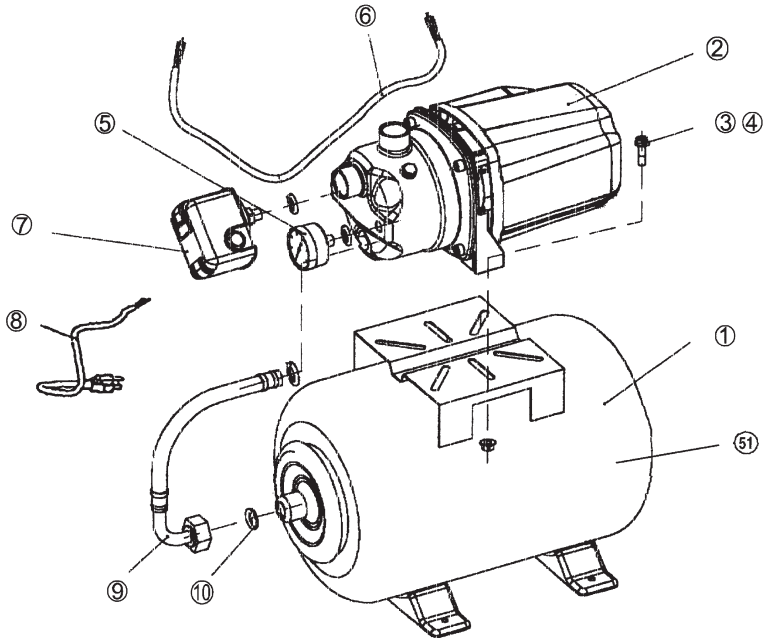

NOTE: Some parts are listed and shown for illustration purposes only and are not available individually as replacement parts.

Parts List A

Part	Description	Qty.
1A	Compression Tank	1
2A	Pump Assembly	1
3A	Hex Bolt	2
4A	Hex Nut	2
5A	Pressure Meter	1
6A	Cable	1
7A	Switch	1
8A	Cord	1
9A	Tube	1
10A	Sealed Latex	1
51(A)	Rubber Bladder	1